



T: +44 (0) 1707 663 883
 F: +44 (0) 1707 663 882
 E: info@orlight.com
 W: www.orlight.com

21B Cranborne Industrial Estate
 Cranborne Road
 Potters Bar, Herts
 EN6 3JN, UK

Luminaire Specification

Orlight Code	Alt Ref	Product Image	Description
Ezential	N/A		<p>Die Cast Aluminium Solid State LED Fixture. Direct 6 Inch Replacement for 2 x 13W Compact Fluorescent Downlights. Low Energy Lighting Solution Offering Maintenance Free Proposition. White Powder Coating Ensures No Colour Degradation.</p>

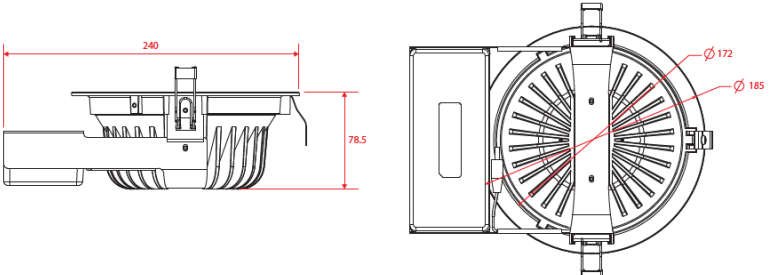
Manufacturer Details	Spec Image	Accessories / Notes
<p>Orlight Ltd. 21B Cranborne Ind. Est. Cranborne Road, Potters Bar, Hertfordshire, EN6 3JN Tel: 01707 663 883 Fax: 01707 663 882 www.orlight.com</p>		<p>Please Refer to Adjacent Diagram</p>
Lamp Type	Solid State LED – 5500-6500K (Cool White)	
Power Consumption	23W	
Lumens	1100	
Input Voltage	220-240	